

## 4-way 6A Curtain Actuator

Manual-Ver2.1

MC0406

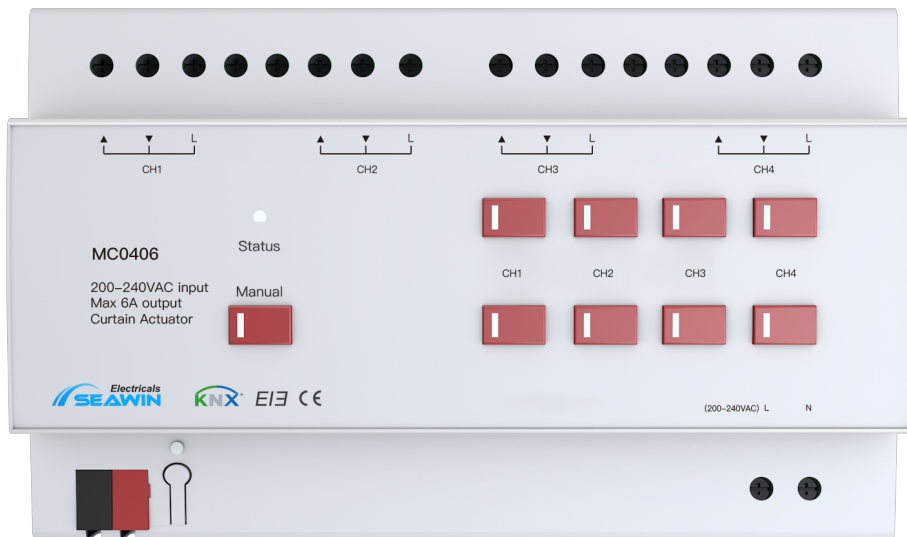

## **Content**

1 Overview .....	1
2 Product and function overview.....	1
3 Detailed parameters .....	1
4 Dimensional drawing and wiring diagrams.....	2
5 Product operation instruction .....	3
6 Parameter setting and communication object description .....	3
6.1 Parameter setting of curtain control function .....	3
6.2 Setting of dry contact interface parameters .....	6
6.3 Device Situation.....	9
6.4 Communication object description .....	10
7 Safe use and maintenance.....	12
8 Contact .....	13

## 1 Overview

This manual provides you with detailed technical information for curtain actuator module, including installation and programming details, and explains how to use the curtain actuator module based on practical examples. To facilitate installation to the distribution box, the curtain actuator module is designed as a modular installation device that can be mounted on a 35 mm DIN rail.

The curtain actuator module is used to control the opening and closing of curtains, etc..

The system is installed with other loads through the EIB/ KNX bus.

Set up and operate the whole system using engineering design tool software ETS.

## 2 Product and function overview

The curtain actuator modules are modular installation devices with 2-way and 4-way outputs. EIB bus terminals are connected to EIB/KNX system, and ETS software (version ETS4.0 or above) is used for physical address allocation and parameter setting.

The maximum load current for output of each curtain actuator is 6A, including 4-way intelligent relays with manual control buttons, LED indicates the switch status of each circuit.

Functions:

- (1) Independently control 4 circuits of AC motor;
- (2) With manual control curtain / projection curtain function;
- (3) You can set the time interval to cycle on or off;
- (4) With field save and restore functions;
- (5) Status value query reply function;
- (6) Selection function of relay switch state after bus power failure and voltage recovery;
- (7) With scene combination control function;
- (8) 4-way dry contact input interface, which can input control instructions such as switches, curtains, dimming, and scenes, and can be directly linked to fire emergency lighting;
- (9) Range of application: opening and closing curtains, projection curtains, jalousie, rolling shutters, elevators, etc.;
- (10) I / O wiring communication distance: less than 10m;

## 3 Detailed parameters

Rated voltage	200~240VAC
Frequency	50/60Hz
Bus voltage	21-30V DC
Bus current	≤12mA
Working frequency:	≤1.6W

Output current (per circuit)	max 6A
Size (Lx W x H)	145mmX90mmX64mm
Weight (approx.)	0.4KG
Shell material	PA66
Installation method	DIN rail installation
Working temperature	- 5°C...+45°C
Storage temperature	-25°C...+ 55°C
Transport temperature	-25°C...+ 70°C
Relative humidity	max 90%

## 4 Dimensional drawing and wiring diagrams

### 4.1 Dimensional drawing

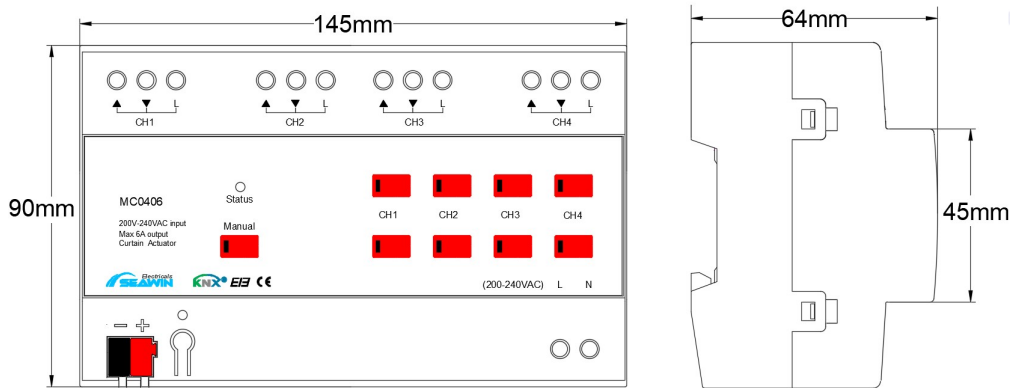

### 4.2 wiring diagram

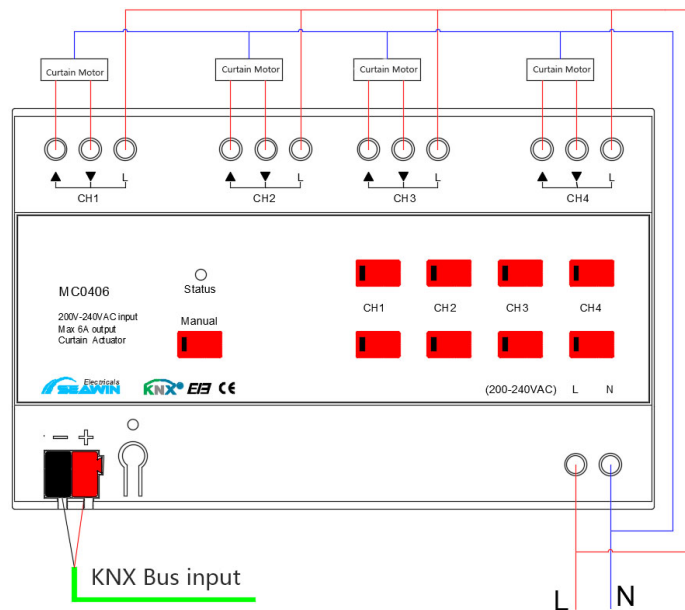

## 5 Product operation instruction

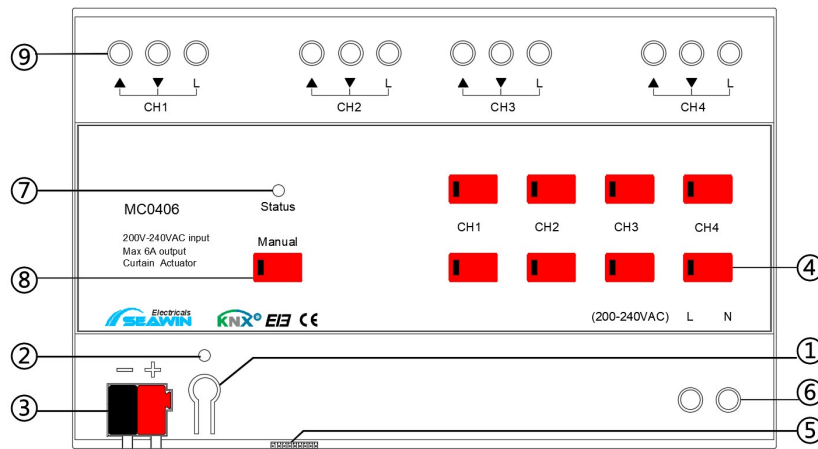

- Description: programming button, short press the button to enter programming mode;
- Description: Programming indicator light, when the indicator light is red, the device is in the programming state, when the device is programmed or working normally, the indicator light is off;
- Description: KNX terminal block, KNX bus connection, the red line is connected to "+", and the black line is connected to "-";
- Instructions: For each circuit control button, when the indicator light on the Manual button is on, long press the upper button, the corresponding circuit curtain motor will run forward, let go to stop; short press the upper row button, the corresponding circuit curtain motor will follow the set range Forward rotation operation; long press the second button, the corresponding circuit curtain motor reverses operation, let go to stop; short press the second button, the corresponding circuit curtain motor reverses according to the set range. (Short press the forward/reverse range to set in the database, the indicator light on the button is on during the operation, and the indicator light is off when the operation is stopped or the operation is completed);
- Description: dry contact input terminals;
- Description: 200~240VAC power supply wiring port, the aperture can be connected to  $\varnothing 4$  wires;
- Note: Status is the status indicator of the device power supply. When the indicator is green, the bus power supply status of the device is normal;
- Explanation: Manual is the switch button for bus and manual control. Press the button once, the indicator light on the button will light up in red, and you can manually control the CH1-CH4 channels.
- Explanation: Relay output terminals: one input and two outputs, "▲" is the terminal for forward rotation of the motor, "▼" is the terminal for reverse rotation of the motor, and the aperture can be connected to  $\varnothing 4$  wires.

## 6 Parameter setting and communication object description

### 6.1 Parameter setting of curtain control function

The following takes ETS5 as an example to set parameters in ETS5. Note: In the following introduction, Channel X or X

represents the output of the corresponding channel.

1) Open the parameter setting interface of the curtain execution module in ETS5, as shown in Figure 6.1.1, the parameter "Channel X" indicates the output of the corresponding channel. The parameter "Field control" indicates the field control function. When the "off" command is sent, the relay status of each channel is saved and closed. When the "on" command is sent, the last saved relay status is recalled. (Note: The "off" command cannot be sent twice consecutively, because the current state is saved when the "off" command is sent for the first time, but when the "off" command is sent for the second time, the "off" command sent for the first time will be saved. off" command, covering the first saved scene state).

Options: Disable

Enable

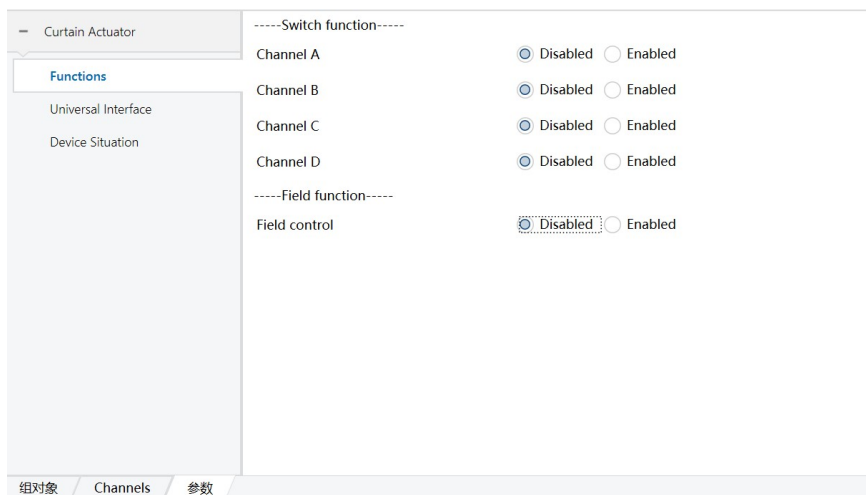

Figure 6.1.1

2) After setting, the interface is shown in Figure 6.1.2, and 4 options in the red block as shown in figure

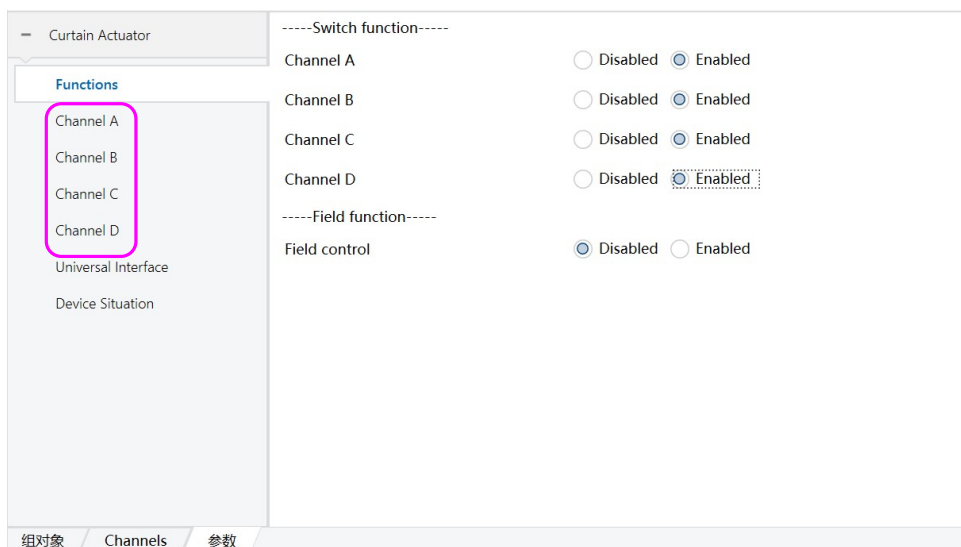

Figure 6.1.2

3) Click the options in the red block above to set the parameters of each circuit. Take Channel A as an example, as shown in figure 6.1.3

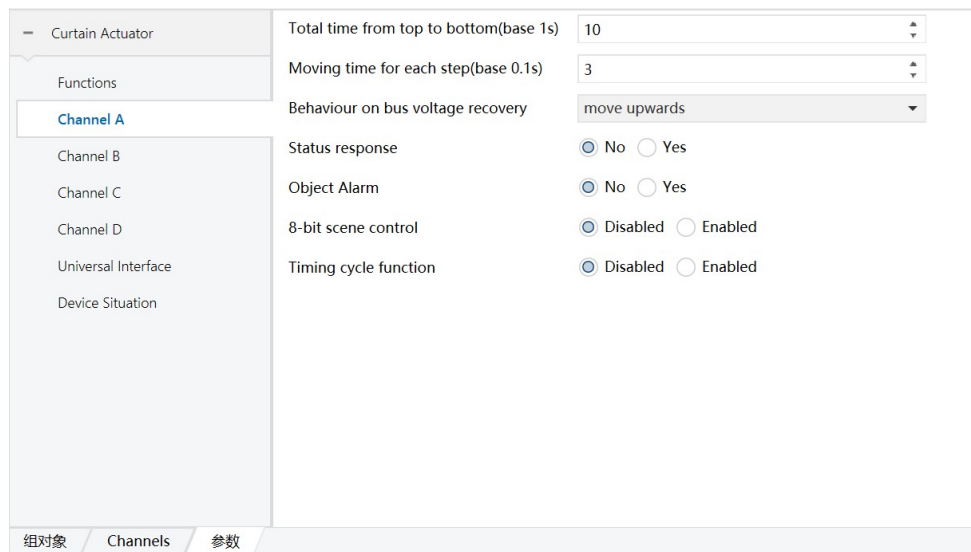

Figure 6.1.3

Parameter	Description
Total time from top to bottom (base 1s)	Total time for curtain from top to bottom, can be filled: 1, 2, 3.....255;
Moving time for each step (base 0.1s)	Indicating the time that the motor rotates when sending a command during jog control, can be filled: 1, 2, 3.....255;
Behaviour on bus voltage recovery	Represents bus voltage recovery status after power failure, options: Move upwards, Move downwards, No action;
Status response	Status response, options: No, Yes, when "Yes" is selected, parameter "Transmission of status" will appear, options: using read request only (Status response only when sending request), on change in status (Status change immediately with status feedback);
Object Alarm	Alarm, options: Yes, No; when "Yes" is selected, "Behavior on alarm" and "Monitoring time for alarm" will appear. "Behavior on alarm" represents alarm status, options: 1%, 2%.....100% (Note: The status x% indicates the percentage of the closed position of the curtain); "Monitoring time for alarm" indicates that the alarm status will be executed automatically after a set time without any instruction to cancel the alarm, options: disabled, 1 minute, 2 minutes.....120 minutes
8-bit scene control	Scene control function, options: Enable, Disable, when "Enable" is selected, "scene" will appear in the corresponding channel on the left side of the interface. Click "scene" and the interface will be switched as shown in figure 6.1.4. In the interface "Channel A assignment 1—8" represents the setting of the scene number, which can be set to 1-64, and "Output Position Value" represents the channel status corresponding to the scene number, which can be filled 0%, 1%.....100%( Note: The status x% indicates the percentage of the closed position of the curtain)
	Timing cycle function, options: Enable, Disable, when "Enable" is selected, "Timing cycle

Timing cycle function	<p>" will appear in the corresponding channel on the left side of the interface, click "Timing cycle", and the interface will be switched as shown in figure 6.1.5. In the interface "Moving direction" indicates the curtain moving direction, options: upwards, downwards; "Operation priority", options: "first moving, then timing", "first timing, then moving"; "Percentage for every movement", options: 0%, 1%, 2%.....100%; "Duration after moving[0-255min]" (in minute), can be filled in: 0, 1, 2.....255; "Duration after moving[0-59s]" (in second), can be filled in: 0, 1, 2.....59; "cycle number (0=unlimited)", can be filled in: Any integer value, "0" means unlimited</p>
-----------------------	---

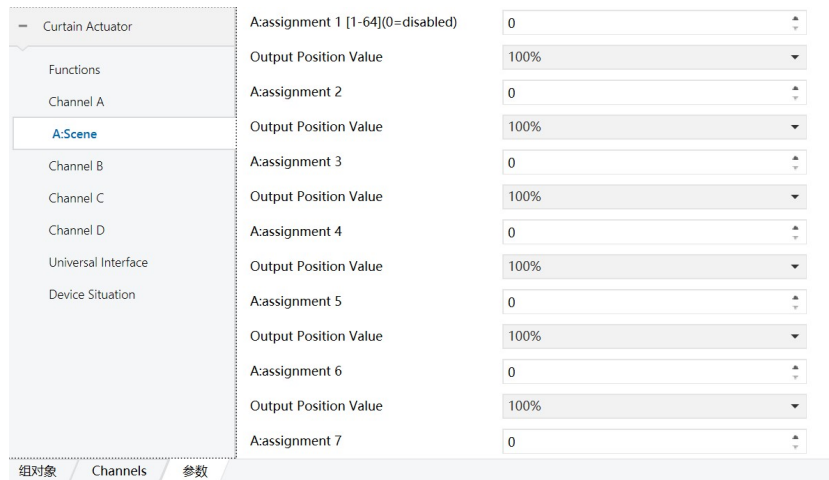

Figure 6.1.4

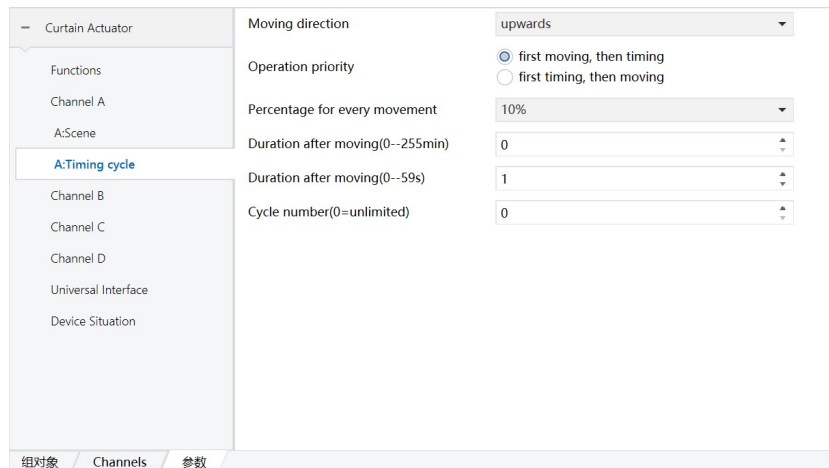

Figure 6.1.5

## 6.2 Setting of dry contact interface parameters

1) Click "Universal Interface" as shown in Figure 6.2.1, Universal Interface A-D is set to enable, four dry contact interfaces will be enabled.



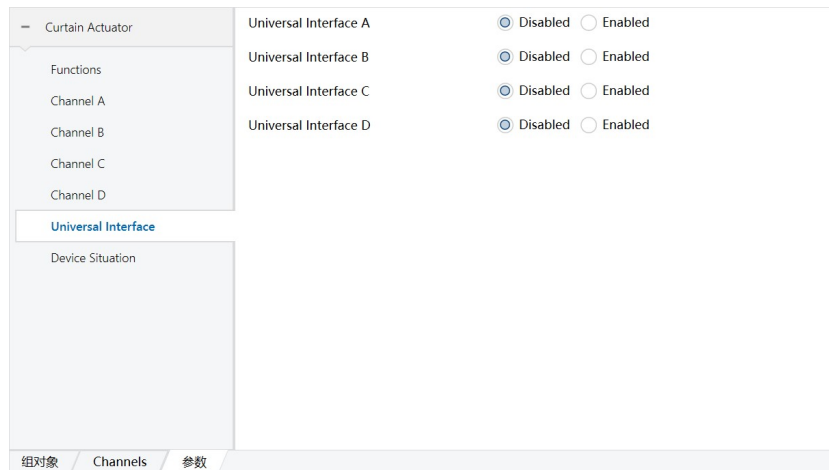

Figure 6.2.1

2) After the setting is completed, there will be Interface A-D four dry contact interfaces on the right. Click each dry contact interface to set its parameters. The following uses Universal Interface A as an example, as shown in Figure 6.2.2.

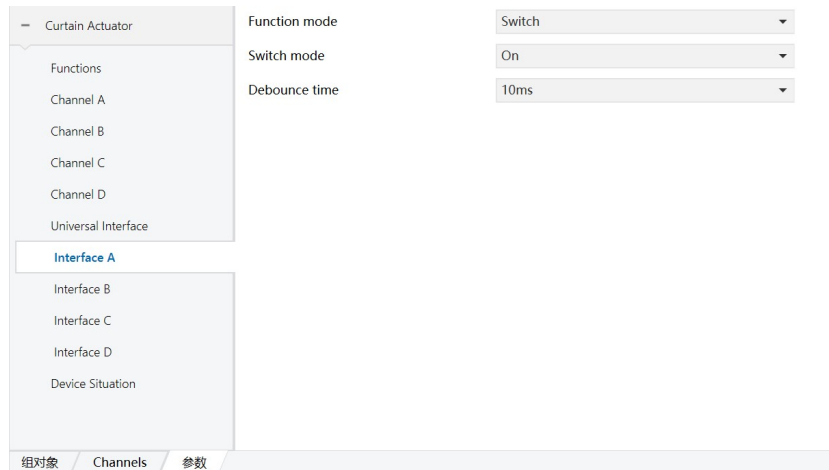

Figure 6.2.2

3) Parameter "function mode" is divided into 6 modes: Switch, Blind, Blind Position, Dimming, Dimming Position, Scene.

(1) Switch mode

Parameter	Description
Switch mode	Represents the action of the corresponding circuit control when the dry contact is triggered, options: on, off, toggle, user define; when user define is selected, The following parameters appear: (1) Reaction on closing the contact, options: on, off, no reaction; (2) Reaction on opening the contact, options: on, off, no reaction; (3) cyclic transmission of object, options: no, if "switch" =ON (relay on) , if "switch" =OFF (relay off) , always. When if "switch" =ON、if "switch" =OFF or always are selected, parameters will appear: transmission cycle time: base and Time factor[1-255] (Here the two parameters indicate the

	time interval between cyclic transmissions, transmission cycle time = base value × Time factor[1-255] value) .
debounce time	Debounce time, options: 10ms, 20ms.....100ms

(2) Blind mode

Parameter	Description
Blind mode	Curtain action controlled by corresponding circuit when dry contact is triggered, options: up, down, toggle;
Long operation	Long press operation, options: yes, no. When yes is selected, parameter “Long operation after” will be added, options: 0.5s, 1s, 2s.....7s; The interval of data(base:0.1s) represents the interval at which each piece of data is sent during a long press, can be filled in: 1, 2, 3 ... 255;
debounce time	Debounce time, options: 10ms, 20ms.....100ms

(3) Blind Position mode

Parameter	Description
Blind value (Range:0-255)0-100%	Represents the percentage of the position of the corresponding circuit control curtain when the dry contact is triggered. It can be filled in: 0-255;
debounce time	Debounce time, options: 10ms, 20ms.....100ms

(4) dimming mode

Parameter	Description
Dimming mode	Represents the dimming action controlled by the corresponding circuit when the dry contact is triggered, options: Dimming up, dimming down, toggle;
Long operation after:	Represents a corresponding action after a long press, options: 0.5s, 1s, 2s.....7s
Transmission mode for long operation	Data transmission mode when long press, options: One-time transmission, cyclic transmission.
Step dimming	Represents the amplitude of dimming, options: 100%、50%、25%、12%、6%、3%、1%
Send stop instruction when releasing	Command to stop when long press is released, options: No, Yes
debounce time	Debounce time, options: 10ms, 20ms.....100ms

(5) Dimming position mode

Parameter	Description
Dimming value (Range:0-255)0-100%	It indicates the brightness percentage of the corresponding circuit control dimming when the dry contact is triggered. It can be filled in: 0-255;
debounce time	Debounce time, options: 10ms, 20ms.....100ms

(6) Scene mode

Parameter	Description
Scene number	Represents the scene number called when the dry contact is triggered. It can be filled in: 1-64;
debounce time	Debounce time, options: 10ms, 20ms.....100ms

### 6.3 Device Situation

1) Click "Device Situation", parameter in Figure 6.3.1 will show:

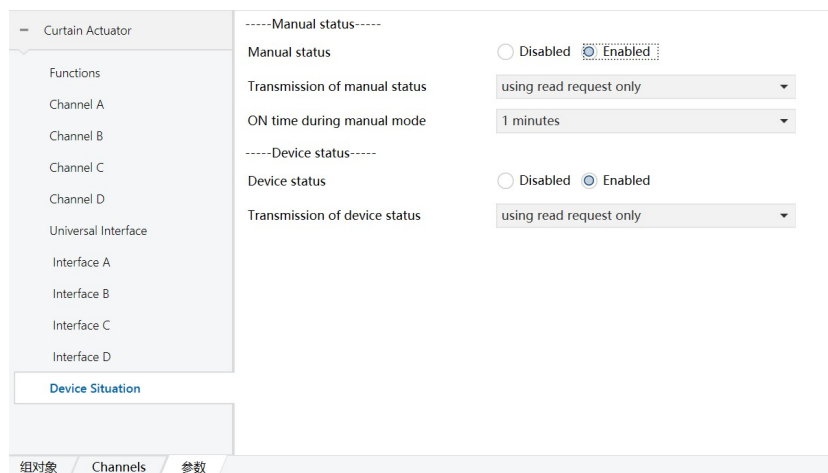

Figure 6.3.1

(1) Manual status indicates manual status. The following parameters appear when "enabled" is selected.

Parameter	Description
Transmission of manual status	Transmission of manual status, options: "using read request only" (Status response only when sending request), "on change in status" (Status change immediately with status feedback), "transmission in cycles"; when "transmission in cycles" is selected, parameter "the time in cycles" (Interval time), will appear, options: 1second, 2seconds..... 120minutes.
ON time during manual mode	ON time during manual mode, options: "1 minute", "2minutes", ".....", "120 minutes", "unlimited".

(2) Device status, the following parameters appear when "enabled" is selected.

Parameter	Description
Transmission of manual status	Transmission of manual status, options: "using read request only" (Status response only when sending request), "on change in status" (Status change immediately with status feedback), "transmission in cycles"; when "transmission in cycles" is selected, parameter "the time in cycles" (Interval time), will appear, options: 1second, 2seconds..... 120minutes.

## 6.4 Communication object description

The communication object is the medium for the device to communicate with other devices on the bus, that is, only the communication object can perform bus communication. The role of each communication object is described in detail below.

The curtain actuator has a total of 62 objects, as shown in Figure 6.4.1, and the specific functions are shown in Table 1.1.

Note: in the column of table properties, "C" represents the communication function enable of the communication object, "W" represents the value of the communication object can be rewritten through the bus, "R" represents the value of the communication object can be read through the bus, "T" represents the communication object has the transmission function, and "U" represents the value of the communication object can be updated.

Number	Name	Object Function	Description	Group Addresses	Length	C	R	W	T	U	Data Type	Priority
0	Status direct mode	On / Off			1 bit	C	R	-	T	-	1 bit DPT_Switch	Low
1	Field switch	Recover / Save and...			1 bit	C	R	W	T	-	1 bit DPT_Switch	Low
2	Channel A, Alarm	Alarm:On/Off			1 bit	C	R	W	T	-		Low
3	Channel A,Scene	8-bit Scene Number			1 Byte	C	R	W	T	-		Low
4	Channel A, Curtain	Up / Down			1 bit	C	R	W	T	-	1 bit DPT_UpDown	Low
5	Channel A, Stop / Step	Stop/Step			1 bit	C	R	W	T	-		Low
6	Channel A,Position value	8-bit Value			1 Byte	C	R	W	T	-	8 bit unsigned val...	Low
7	Channel A, Timing cycle	On / Off			1 bit	C	R	W	T	-	1 bit DPT_Switch	Low
8	Channel A, Status curtain	Position 0-100%			1 Byte	C	R	-	T	-	8 bit unsigned val...	Low
9	Channel B, Alarm	Alarm:On/Off			1 bit	C	R	W	T	-		Low
10	Channel B,Scene	8-bit Value			1 Byte	C	R	W	T	-		Low
11	Channel B, Curtain	Up / Down			1 bit	C	R	W	T	-	1 bit DPT_UpDown	Low
12	Channel B, Stop / Step	Stop/Step			1 bit	C	R	W	T	-		Low
13	Channel B,Position value	8-bit Value			1 Byte	C	R	W	T	-	8 bit unsigned val...	Low
14	Channel B, Timing cycle	On / Off			1 bit	C	R	W	T	-	1 bit DPT_Switch	Low
15	Channel B, Status curtain	Position 0-100%			1 Byte	C	R	-	T	-	8 bit unsigned val...	Low
16	Channel C, Alarm	Alarm:On/Off			1 bit	C	R	W	T	-		Low
17	Channel C,Scene	8-bit Value			1 Byte	C	R	W	T	-		Low
18	Channel C, Curtain	Up / Down			1 bit	C	R	W	T	-	1 bit DPT_UpDown	Low
19	Channel C, Stop / Step	Stop/Step			1 bit	C	R	W	T	-		Low
20	Channel C,Position value	8-bit Value			1 Byte	C	R	W	T	-	8 bit unsigned val...	Low
21	Channel C, Timing cycle	On / Off			1 bit	C	R	W	T	-	1 bit DPT_Switch	Low
22	Channel C, Status curtain	Position 0-100%			1 Byte	C	R	-	T	-	8 bit unsigned val...	Low
23	Channel D, Alarm	Alarm:On/Off			1 bit	C	R	W	T	-		Low
24	Channel D,Scene	8-bit Value			1 Byte	C	R	W	T	-		Low
25	Channel D, Curtain	Up / Down			1 bit	C	R	W	T	-	1 bit DPT_UpDown	Low
26	Channel D, Stop / Step	Stop/Step			1 bit	C	R	W	T	-		Low
27	Channel D,Position value	8-bit Value			1 Byte	C	R	W	T	-	8 bit unsigned val...	Low

Figure 6.4.1

Number	Name	Communication object function	Data type	Attribute
0	Manual mode and status	On/Off	1 bit	C,R,T
<p>The communication object is enabled when the parameter " Manual status " selects "Enable", this communication object is used to indicate the switch of manual mode (Manual mode=on) and bus mode (Manual mode=off) . When switching to manual mode (press the bus on the switch actuator and the manual control switch button, the "Manual" indicator lights up), you can control the on / off of each circuit on the corresponding button on the module. When switching to the bus mode (press the bus on the switch actuator and the manual control switch button again, the "Manual" indicator turns off), it responds only the operations on the bus.</p>				
1	Field switch	Recover/Save and Off	1 bit	C,R,W,T
<p>The communication object is enabled when the parameter "Field control" selects "Enable". When the communication object receives the value "0", the channel status of the device is saved and all channels are closed; when the communication object receives the value "1" recall the last saved scene state.</p>				

2, 9, 16,23	Channel X, Alarm	Alarm:On/Off	1 bit	C,R,W,T
This communication object is enabled when the parameter " Object Alarm " of "Channel X" selects "Yes". When the communication object receives 0, alarm off; when it receives 1, alarm on				
3,10,17,24	Channel X, Scene	8-bit Scene Number	1 Byte	C,R,W,T
This communication object is enabled when the parameter "8-bit scene control " of "Channel X" selects "Enable". This communication object can send a 1-byte command to call the setting operation of corresponding scene number. The parameter setting options are 1 ~ 64. In fact, the scene message received by the communication object Scene, Channel X is 0 ~ 63. If the parameter is set to scene 1, the communication object Scene, Channel X receives the scene is 0				
4,11,18,25	Channel X, Curtain	Up/Down	1 bit	C,R,W,T
This communication object is enabled when "Enable" is selected for "Channel X". When the communication object receives the value "0", the curtain moves to the 0% position (the curtain is open). When the communication object receives the value "1", The curtains are moved to the 100% position (the curtains are closed).				
5,12,19,26	Channel X, Stop/Step	Stop/Step	1 bit	C,R,W,T
This communication object is enabled when "Enable" is selected for "Channel X". This communication object is used for the jog operation of the curtain.				
6,13,20,27	Channel X, Position value	8-bit Value	1 Byte	C,R,W,T
This communication object is enabled when "Enable" is selected for "Channel X". This object is used to receive the absolute rotation value of the corresponding output channel.				
7,14,21,28	Channel X, Timing cycle	On/Off	1 bit	C,R,W,T
This communication object is enabled when " Timing cycle function " in " Channel X " selects "Enable", when the communication object receives the value "1", the curtain motor's cyclic rotation function is executed; when the communication object receives the value "0", the cyclic rotation function stops				
8,15,22,29	Channel X, Status curtain	Position 0%-100%	1 byte	C,R,T
This communication object is enabled when " Status response " in " Channel X " selects "Enable", the value of this communication object can directly indicate the position of the curtains of the corresponding channel (Note: the status x% represents the percentage of the curtain closed to the position, for example: 0% means that the curtain is open and 100% means that the curtain is closed)				
30,38,46,54	Switch, Interface X	On/Off	1 bit	C,R,W,T
This communication object is enabled when "Function mode" in "Interface X" selects "Switch". When the dry contact is triggered, the channel sends corresponding ON or OFF instructions according to the corresponding mode.				
31,39,47,55	Blind, Interface X	Up/Down	1 bit	C,R,W,T
This communication object is enabled when "Function mode" in "Interface X" selects "Blind", when the dry contact is triggered, the channel sends the corresponding up or down instruction according to the corresponding mode.				
32,40,48,56	Blind, long, Interface X	Up/Down	1 bit	C,R,W,T
This communication object is enabled when "long operation" in "Blind" of "Interface X" selects "yes", when the dry				

contact is triggered by long press, the channel sends the corresponding up or down instruction according to the corresponding mode.				
33,41,49,57	Blind value, Interface X	8-bit value	1 Byte	C,R,W,T
This communication object is enabled when "Function mode" in "Interface X" selects "Blind position", when the dry contact is triggered, the channel sends the corresponding curtain height percentage instruction according to the corresponding mode.				
34,42,50,58	Dimming switch, Interface X	On/Off	1 bit	C,R,W,T
This communication object is enabled when "Function mode" in "Interface X" selects "Dimming", when the dry contact is triggered by a short press, the channel sends the corresponding dimming on/off instruction according to the corresponding mode.				
35,43,51,59	Dimming level, Interface X	Brighter/Darker	4 bit	C,R,W,T
This communication object is enabled when "Function mode" in "Interface X" selects "Dimming", when the dry contact is triggered by a long press, the channel sends corresponding series of relative dimming instructions according to the corresponding mode				
36,44,52,60	Dimming value, Interface X	8-bit value	1 Byte	C,R,W,T
This communication object is enabled when "Function mode" in "Interface X" selects "Dimming position", when the dry contact is triggered, the channel sends absolute dimming instructions according to the setting percentage.				
37,45,53,61	Scene, Interface X	8-bit value	1 Byte	C,R,W,T
This communication object is enabled when "Function mode" in "Interface X" selects "Scene", when the dry contact is triggered, the channel sends corresponding scene control instructions according to the corresponding mode.				
62c	Device status	On/Off	1 bit	C,R, T
This communication object is enabled when the parameter "Device status" is selected to be "enabled". This communication object is used to detect the current condition of the device. When the value "01" is sent through this object, it indicates that the 220V power supply is normal. When the value "00" is sent, it indicates that the 220V power supply is abnormal.				

Table 1.1

## 7 Safe use and maintenance

- (1) Read all instructions carefully before use.
- (2) Create a good ventilation environment.
- (3) During use, pay attention to moisture, shock and dust.
- (4) Strictly forbid to rain, contact with other liquids or corrosive gases.
- (5) If it is wet or attacked by liquid, it should be dried in time.
- (6) When the machine fails, please contact professional maintenance personnel or our company.

## **8 Contact**

Address: 9th Floor, Building 5, Aotelang Science and Technology Park, No. 68, Nanxiang 1st Road, Huangpu District, Guangzhou City, Guangdong Province, China

Tel: +86-20-82189121

Fax: +86-20-82189121

Website: <http://www.seawin-knx.com>